

## Versatile Refueling Filter

## Product Bulletin

---

### FBO Filter Assembly

Racor Hydrocarbon Filters' new FBO-10 and FBO-14 filter assemblies were designed to meet the toughest hydrocarbon refueling conditions and give maintenance personnel ease of filter change outs. The FBO Assembly can flow 25gpm/95lpm or up to 60gpm/230lpm depending on the unit, elements installed and fuels being filtered.

The FBO assembly can be used on mobile refuelers or installed in refueling cabinets. The unit can also be used for diesel fuel dispensing pumps or as a primary fuel filter/water separator for large diesel engines.

The assembly features a "locking ring collar", which attaches the filter housing to the aluminum die cast filter head with four bolts. The slotted "locking ring collar" allows maintenance personnel to hand loosen the four collar bolts, rotate and lower the bowl assembly for element change outs. With new element installed, simply raise the bowl and rotate into position on the locking ring and hand tighten evenly.

The closure hardware consists of stainless steel nuts, bolts, and washers with metal hand knobs for ease of maintenance. No wrenches or other special tools required.

***No V-Band Clamps are used allowing one person to easily change the filter element.***

#### Applications:

- x Jet fuel, Aviation gas, diesel fuel, gasoline, kerosene, JP4, JP5 and JP8.

#### Installations:

- x Aviation fuel trucks
- x Aviation fueling cabinets
- x Diesel fuel dispensing system
- x Marine fuel docks
- x Fuel systems on large diesel engines

#### Standard Design Features:

- x Die-cast aluminum head
- x Steel filter bowl assembly
- x Powder coated components
- x "Locking ring collar", no clamps
- x 1 1/2" NPT Inlet and Outlet
- x 150psi @ 240°F max design pressure
- x Manual drain valve
- x Manual vent valve



#### Optional Accessories:

- x Water sight glass or electronic water probe
- x Delta P indicator

#### Element Options: (micron)

- x FP Prefilters: 1, 5, 10 & 25
- x OCP Coalescers: 1, 5, 10, & 25
- x FW Water Absorbing: 1, 5, 10, & 25

6/15/02

	Maximum Flow Rate			Clean Dry	Change	
	Flow Range	Diesel	Jet Fuel	Gasoline	Delta P	Delta P
<b>FBO-10</b>						
Prefilter	5-40 GPM	20	40	50	**	20 PSID
Filter Separ	5-35 GPM	18	35	45	**	15 PSID
Absorber	5-25 GPM	18	35	45	**	30 PSID
<b>FBO-14</b>						
Prefilter	10-60 GPM	30	60	75	**	20 PSID
Filter Separ	10-50 GPM	25	50	65	**	15 PSID

\*\*varies with fluid and flow rate

### FBO-10 and FBO-14 Specifications

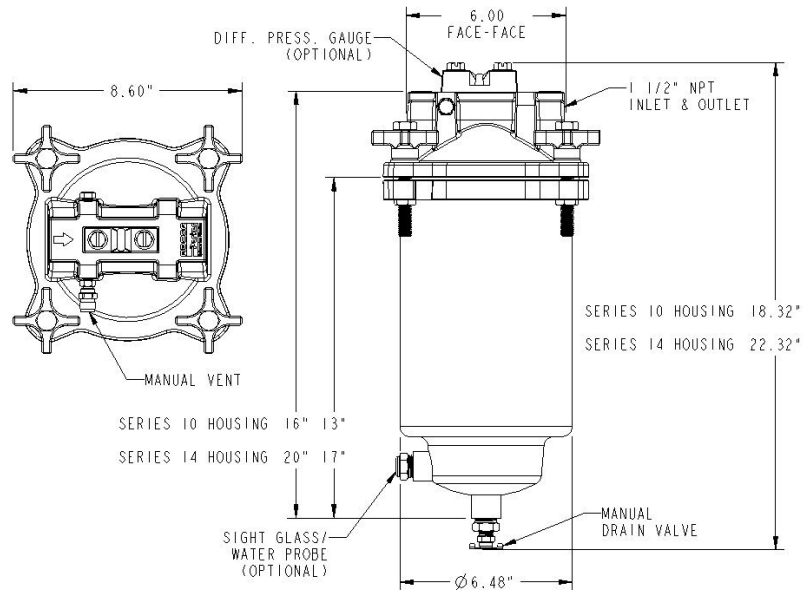

### Element Applications

	Micron Rating	FBO-10	FBO-14
		<b>6 X 10 Element</b>	<b>6 X 14 Element</b>
<b>Filter Separator</b>	<b>1</b>	<b>FBO-60327</b>	<b>FBO-60336</b>
	<b>5</b>	<b>FBO-60328</b>	<b>FBO-60337</b>
	<b>10</b>	<b>FBO-60353</b>	<b>FBO-60356</b>
	<b>25</b>	<b>FBO-60329</b>	<b>FBO-60338</b>
<b>Prefilter</b>	<b>1</b>	<b>FBO-60330</b>	<b>FBO-60339</b>
	<b>5</b>	<b>FBO-60331</b>	<b>FBO-60340</b>
	<b>10</b>	<b>FBO-60356</b>	<b>FBO-60357</b>
	<b>25</b>	<b>FBO-60332</b>	<b>FBO-60341</b>
<b>Absorptive Filter</b>	<b>1</b>	<b>FBO-60333</b>	<b>FBO-60342</b>
	<b>5</b>	<b>FBO-60334</b>	<b>FBO-60343</b>
	<b>10</b>	<b>FBO-60355</b>	<b>FBO-60358</b>
	<b>25</b>	<b>FBO-60335</b>	<b>FBO-60344</b>

